



## INSTALLATION MANUAL

FOR THE

**KD130GX-LPU~KD185GX-LPU**

OF

SOLAR PHOTOVOLTAIC POWER MODULES

Please read this manual carefully before installing the modules.

KYOCERA

6C-207112

### 1. INTRODUCTION

As the world leader in the development and application of high technology ceramic/silica materials, Kyocera offers a wide range of highly efficient and reliable crystalline silicon solar photovoltaic (PV) power modules. Kyocera began to extensively research PV technology in 1975 and commenced manufacturing operations in 1978. Since then, Kyocera has supplied millions of cells and modules throughout the world. With years of experience and state-of-the-art technology, Kyocera provides the highest quality PV power modules in a range of sizes designed to meet the requirements of the most demanding energy and power users worldwide.

### 2. APPLICATIONS

KDxxxGX-LPU series modules are a reliable, virtually maintenance-free direct current (DC) power source, designed to operate at the highest level of efficiency.

KDxxxGX-LPU series modules are ideal for remote home, water pumping, utility-tied, telecommunications and many other applications either with or without using storage batteries.

### 3. WARNINGS & SAFETY

PV modules generate electricity when exposed to light. Arrays of many modules can cause lethal shock and burn hazards. Only authorized and trained personnel should have access to these modules. To reduce the risk of electrical shock or burns, modules may be covered with an opaque material during installation. Do not touch live terminals with bare hands. Use insulated tools for electrical connections. Do not use these modules for solar concentration.

#### PERMIT

- Before installing your PV system, contact local authorities to determine the necessary permits, installation and inspection requirements.

#### INSTALLATION AND OPERATION

- Systems should be installed by qualified personnel only. The system involves electricity, and can be dangerous if

the personnel are not familiar with the appropriate safety procedures.

- **Do not step on the module.**
- Although KDxxxGX-LPU series modules are quite durable, the glass can be broken (and the module will no longer work properly) if it is dropped or hit by tools or other objects.
- The module frame is made of anodized aluminum, and therefore corrosion can occur if the module is subject to a salt-water environment and is in contact with another type of metal (electrolytic corrosion). If required, PVC or stainless steel washers can be placed between PV module frame and support structure to prevent this type of corrosion.
- KDxxxGX-LPU series module frame(s) must be attached to a support structure by one of the methods described in Section 6, Installing KDxxxGX-LPU series module(s).
- Module support structures to be used to support KDxxxGX-LPU series module(s) should be wind rated and approved by the appropriate local and civil codes prior to installation.
- Do not expose the back of the module to direct sunlight
- In Canada installation shall be in accordance with CSA C22.1, Safety Standard for Electrical Installations, Canadian Electrical Code, Part 1.

#### FIRE RATING

- In case of roof installation, PV module assembly shall be mounted on a fire resistant roof covering rated for the application. KDxxxGX-LPU series modules are comprised of a glass front surface, polyethylene terephthalate (PET) backsheet with a Class C fire rating.

#### GROUNDING

- Refer to "Grounding" section.

#### BATTERY

- When PV modules are used to charge batteries, the battery must be installed in a manner, which will ensure the performance of the system and the safety of its users. **Follow the battery manufacturer's safety guidelines concerning installation, operation and maintenance recommendations.** In general, the battery (or battery bank) should be kept away from people and animals. Select a battery site that is protected from sunlight, rain, snow, debris, and is well ventilated. Most batteries generate hydrogen gas when charging, which can be explosive. Do not light matches or create sparks near the battery bank. When a battery is installed outdoors, it should be placed in an insulated and ventilated battery case specifically designed for this purpose.

### 4. SITE SELECTION

In most applications, KDxxxGX-LPU series modules should be installed in a location where they will receive maximum sunlight throughout the year. In the Northern Hemisphere, the modules should typically face south, and in the Southern Hemisphere, the modules should typically face north. Modules facing 30 degrees away from true South (or North) will lose approximately 10 to 15 percent of

their power output. If the module faces 60 degrees away from true South (or North), the power loss will be 20 to 30 percent. When choosing a site, avoid trees, buildings or obstructions, which could cast shadows on PV modules especially during the winter season when the arc of the sun is lowest over the horizon.

## 5. MODULE TILT ANGLE

KDxxxGX-LPU series modules produce bigger power when they are pointed directly at the sun.

For grid tie installations where the PV modules are attached to a permanent structure, PV modules should be tilted at an angle equal to the site's latitude. This will typically result in the highest annual energy output.

## 6. INSTALLING KDxxxGX-LPU SERIES MODULES

To install the module, use bolt and nut on installation holes which are opened in the module frame and install the module by following the instruction below.

The minimum spacing of .6" (15 mm) is required between PV module and the mounting surface around the perimeter of PV module. KDxxxGX-LPU series modules may be installed in various applications utilizing a variety of support structure options and attachment methods. For optimal performance in all applications, clearance between the module frame and the mounting surface is required to allow cooler ambient air to circulate around the back of the module and to avoid the module and / or wiring damage. A minimum of .13" (3.2 mm) spacing must also be maintained between module frames to allow for thermal expansion.

KDxxxGX-LPU series modules may be attached to a support structure by the following methods. When installing modules in snowy area, countermeasures for possible damage to the lower side frame from slipping snow are recommended to be taken (e.g. attach supporting parts to the lowest modules.).

**BOLTING:** Utilizing 5/16" or 8 mm steel hardware structure through the existing .35" (9 mm) diameter mounting holes in the module frame and then through KDxxxGX-LPU series module mounting holes on the support structure. Tighten the screws with adequate torque (usually 132 in-lb). Refer to the Module Drawings for the position of PV module mounting holes.

## 7. MODULE WIRING

KDxxxGX-LPU series modules come pre-wired with terminals ready for most building attachments or free standing installations. Each module has two #12 AWG type USE-2/RHH/RHW-2 stranded sunlight resistant output cables each terminated with Multi-Contact® locking connectors. The positive (+) terminal has a male connector while the negative (-) terminal has a female connector. The module wiring is solely for series connections only, i.e. male (+) to female (-) interconnections. Series and parallel connections shall be made by use of two #10-14 AWG type XLPE sunlight resistant output cables with male and female

Multi-Contact® locking connectors.

**NOTE:** When making connections with Multi-Contact connectors, make sure the array is disabled. **DO NOT MAKE CONNECTIONS WHILE UNDER LOAD.** Module output connections are marked "Do not disconnect under load".

**NOTE: MAXIMUM SYSTEM VOLTAGE 600 VDC.**

KDxxxGX-LPU series modules and most PV system components have a maximum system voltage rating of 600 volts DC. Some grid feed in systems operate at or near this voltage rating. Like other polycrystalline the PV modules, the open circuit voltage of the KDxxxGX-LPU series modules increases as the ambient temperature decreases. Maximum system voltage is computed as the sum of the open-circuit voltage of the series-connected PV modules for the lowest expected ambient temperature. Refer to the National Electrical Code Article 690-7(a) for determining the maximum number of KDxxxGX-LPU series modules that can be placed in series. Temperature coefficients, specific to the module of use, can be used to provide the most accurate prediction of module voltage under temperature extremes.

**NOTE:** Install the maximum number of series connection for the KDxxxGX-LPU series modules so that the system voltage is less than 600 V.

**NOTE:** Do not connect the modules in parallel without maximum over current protection.

**NOTE:** The minimum diameter that the cable can be bent for the KDxxxGX-LPU series modules is 1.93" (49mm).

**NOTE:** In normal conditions, PV modules may produce larger current and / or voltage than reported in the standard test conditions. Therefore, when voltage evaluations for components, capacity of conductors, size of fuses, and size of control systems connected to the module output are determined, multiply the values of short-circuit current (Isc) and open-circuit voltage (Voc) that are marked in KDxxxGX-LPU series modules by the coefficient, 1.25.

## 8. GROUNDING

Before installation, contact the local code authorities to determine the necessary grounding requirements. When installing in US market, attach all PV module frames to an earth ground in accordance with the National Electrical Code (NEC) Article 250. Proper grounding is achieved by connecting PV module frames and all metallic structural members contiguously to one another using a suitable grounding conductor. The grounding conductor shall be of copper, copper alloy or another material suitable for use as an electrical conductor per NEC. The grounding conductor must then make a connection to earth using a suitable earth grounding electrode. Ensure positive electrical contact through the anodizing on the module frame extrusion by utilizing one of the following methods. Attach the grounding conductor:

- (1) to one of the .35" (9mm) diameter holes marked "ground" using 5/16" stainless steel hardware. Wrap conductor around bolt. Tighten the screws with adequate torque (usually 132 in-lb). Avoid direct contact of copper ground conductor to aluminum frame.

(2) to a ground lug (manufacturer: ILSCO, model: GBL-4DBT).

Tighten the screws with adequate torque (usually 62 in-lb). Use #10-32 stainless steel hardware to attach the lug to the module frame by the torque of 40 in-lb. A stainless steel star washer, positioned between the lug and the anodized surface of the frame, must be employed to break through the anodized layer of the frame extrusion and electrically connect the ground lug to the conducting aluminum frame material.

As a general rule, avoid direct contact of copper or copper alloyed ground conductors with the aluminum module frame. All ground bond securing hardware in contact with either the aluminum module frame and / or copper or copper alloy ground conductors must be stainless steel.

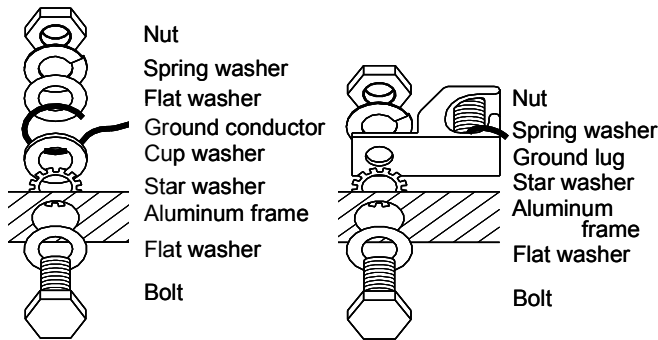

## 9. BLOCKING DIODES

In systems utilizing a battery, blocking diodes are typically placed between the battery and PV module output to prevent battery from discharging at night. KDxxxGX-LPU series modules are made of polycrystalline cells with high electrical "back flow" resistance to nighttime battery discharging. As a result, KDxxxGX-LPU series modules do not contain a blocking diode when shipped from the factory. Most PV charge regulators and inverters incorporate nighttime disconnect feature.

## 10. BYPASS DIODES

Partial shading of an individual module in a source circuit string (i.e. two or more modules connected in series) can cause a reverse voltage across the shaded cells within the module. Module output current is then forced through the shaded area by the remaining illuminated cells and other PV modules in series with the partially shaded module(s). The current forced through the shaded cells within PV module (or modules) causes additional module heating and severe loss of power. All KDxxxGX-LPU series modules are supplied with factory installed (non user serviceable) bypass diodes.

The purpose of bypass diodes is to provide a low-resistance current path around the shaded cells, thereby minimizing PV module heating and array current losses.

PV modules employ bypass diodes that have:

- Rated Average Forward Current [ $I_{F(AV)}$ ] **Above** maximum system current at highest PV module operating temperature.
- Rated Repetitive Peak Reverse Voltage [ $V_{RRM}$ ] **Above** maximum system voltage at lowest PV module operating temperature.

## 11. MAINTENANCE

KDxxxGX-LPU series modules are designed for long life and require very little maintenance. Under most weather conditions, normal rainfall is sufficient to keep the module glass surface clean. If dirt build-up becomes excessive, clean the glass surface only with a soft cloth using mild detergent and water. **USE CAUTION WHEN CLEANING THE BACK SURFACE OF PV MODULE TO AVOID PENETRATING BACK SHEET.** PV modules that are mounted flat ( $0^\circ$  tilt angle) should be cleaned more often, as they will not "self clean" as effectively as modules mounted at a  $15^\circ$  tilt or greater. Once a year, check the general condition of the wiring and check to be sure that mounting hardware is tight. Loose connections may result in a damaged module or array.

### KYOCERA Solar Group Sales Office

■ KYOCERA Corporation  
Corporate Solar Energy Division  
6 Takeda Tobadono-cho Fushimi-ku, Kyoto 612-8501, Japan  
Phone: 81-75-604-3476  
Fax: 81-75-604-3475  
<http://www.kyocera.com/>

■ KYOCERA Solar, Inc.  
7812 East Acoma Drive, Scottsdale, AZ 85260, U.S.A.  
Phone: 1-480-948-8003 or 1-800-223-9580  
Fax: 1-480-483-6431  
<http://www.kyocerasolar.com/>

■ KYOCERA Solar Pty Ltd.  
Level 3, 6-10 Talavera Road, North Ryde NSW 2113, Australia  
Phone: 61-2-9870-3946  
Fax: 61-2-9888-9673  
<http://www.kyocerasolar.com.au/>

■ KYOCERA Solar do Brasil Ltda.  
Av. Guignard 661, Loja A  
Recreio dos Bandeirantes-Rio de Janeiro, Brazil, 22790-200  
Phone: 55-21-2437-8585  
Fax: 55-21-2437-2338  
<http://www.kyocerasolar.com.br/>

■ KYOCERA Fineceramics GMBH  
Fritz-Mueller-Strasse 27, 73730 Esslingen, Germany  
Phone: 49-711-93934-999  
Fax: 49-711-93934-950  
<http://www.kyocerasolar.de/>

■ KYOCERA Asia Pacific Pte. Ltd.  
298 Tiong Bahru Road, #13-03/05 Central Plaza  
Singapore 168730  
Phone: 65-6271-0500  
Fax: 65-6271-0600  
<http://www.kyocera.com.sg/>

■ KYOCERA Asia Pacific Ltd.  
Room 801-802, Tower 1, South Seas Center,  
75 Mody Road, Tsimshatsui East, Kowloon, Hong Kong  
Phone: 852-2-723-7183  
Fax: 852-2-724-4501

■ KYOCERA Asia Pacific Pte. Ltd. Taipei Office  
10 Fl., No.66, Nanking West Road, Taipei, Taiwan  
Phone: 886-2-2555-3609  
Fax: 886-2-2559-4131

- KYOCERA (Tianjin) Sales & Trading Corp.  
Room 2107, Beijing Huabin International Building,  
No.8 Yong An Dong Li Jian Guo Men Wai Road,  
Chao Yang District, Beijing, 100022, China  
Phone: 86-10-8528-8838  
Fax: 86-10-8528-8839  
<http://www.kyocera.com.cn/>
  
- KYOCERA Korea Co., Ltd.  
Diplomatic Center Room #406, 1376-1,  
Secho-2Dong, Seocho-Ku, Seoul, 137-072, Korea  
Phone: 82-2-3463-3538  
Fax: 82-2-3463-3539  
<http://www.kyocera.co.kr/>

## 12. SPECIFICATIONS

- Under certain conditions, a photovoltaic module may produce more voltage and current than reported at Standard Test Conditions (STC). Refer to Section 690 of the National Electrical Code for guidance in series string sizing and choosing overcurrent protection.

### Kyocera KDxxxGX-LPU Series Module Specification

Electrical Characteristics: @ STC				
Module Type	KD130GX-LPU	KD135GX-LPU	KD180GX-LPU	KD185GX-LPU
Pmax	130W +/-5%	135W +/-5%	180W +/-5%	185W +/-5%
Voc	22.1V	22.1V	29.5V	29.5V
Isc	8.06A	8.37A	8.35A	8.58A
Vpm	17.7V	17.7V	23.6V	23.6V
Ipm	7.35A	7.63A	7.63A	7.84A
Factory installed Bypass Diode				
(QTY)	YES(2pcs)		YES (3pcs)	
Series Fuse Rating (A)	15	15	15	15
Thermal Characteristics: Temp. Coefficient				
Voc (V/°C)	$-0.80 \times 10^{-1}$	$-0.80 \times 10^{-1}$	$-1.06 \times 10^{-1}$	$-1.06 \times 10^{-1}$
Isc (A/°C)	$4.84 \times 10^{-3}$	$5.02 \times 10^{-3}$	$5.01 \times 10^{-3}$	$5.15 \times 10^{-3}$
Vpm (V/°C)	$-0.92 \times 10^{-1}$	$-0.92 \times 10^{-1}$	$-1.23 \times 10^{-1}$	$-1.23 \times 10^{-1}$
Physical Characteristics:				
Module Type	KD130GX-LPU	KD135GX-LPU	KD180GX-LPU	KD185GX-LPU
Length	59.1" (1500mm)	59.1" (1500mm)	52.7" (1338mm)	52.7" (1338mm)
Width	26.3" (668mm)	26.3" (668mm)	39.0" (990mm)	39.0" (990mm)
Depth	1.8" (46mm)	1.8" (46mm)	1.8" (46mm)	1.8" (46mm)
Weight	27.6 lb (12.5kg)	27.6 lb (12.5kg)	35.3 lb (16.0kg)	35.3 lb (16.0kg)
Mounting Hole	Diameter .35" (9mm) Quantity 4pcs			
Grounding Hole	Diameter .35" (9mm) Quantity 4pcs			
Application Class	Class A			

### NOTES

- Standard Test Conditions of irradiance of  $1000 \text{ W/m}^2$ , spectrum of air mass 1.5, and cell temperature of 25 deg C.
- See module drawing for mounting and grounding holes locations.

